



SELF-CLIMBING SYSTEMS



// High efficiency for highrise construction



// Table of content

ATR Self-climbing system	2
RKS Rail climbing system	8
HWS Perimeter safety screen	11
Basic components	14



■ ATR Self-Climbing Systems

// Features

Formwork support structure for the construction of walls and other vertical structures without crane assistance (driven by hydraulic and mechanical mechanisms).

The climbing process consists of the successive elevation of the mast and the climbing bracket-formwork-set along the wall surface.



// Main system components

- 1 Self-climbing bracket ATR
- 2 Self-climbing bracket shoe
- 3 Mast
- 4 Cylinder
- 5 Upper climbing head
- 6 Lower climbing head
- 7 Support block
- 8 Anchor bracket
- 9 Formwork

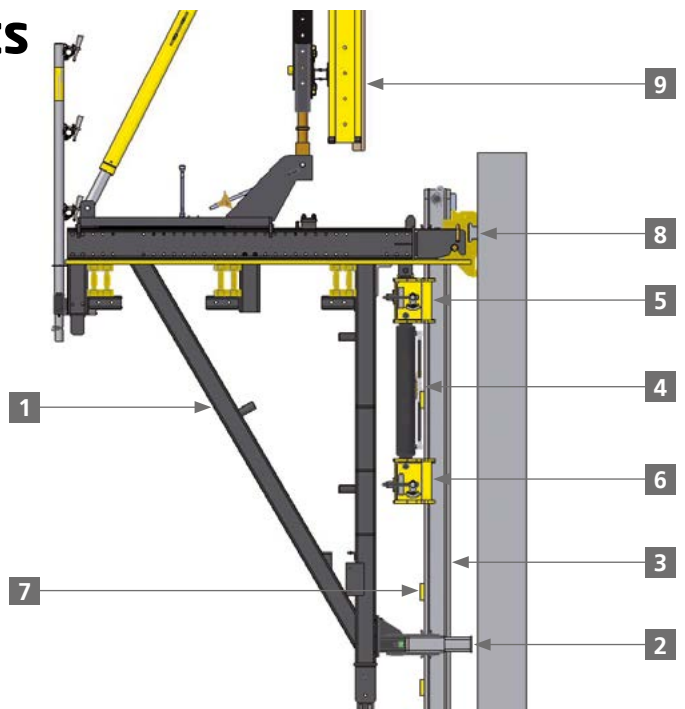



// Benefits

- ▶ **Flexible and versatile** for all requirements in highrise construction.
- ▶ **Versatile, thanks to MK system** components: complex wall geometries, platform configurations, closures, optimised formwork configurations, safety, workspaces between wall and formwork, cone recovery.
- ▶ **Not dependent on crane assistance:** formwork, working platforms and boom concrete pumps can be simultaneously lifted.
- ▶ **Hydraulic climbing:** superior performance compared to conventional climbing with crane. **Very fast construction pace.**
- ▶ Operational even **in adverse weather conditions.**
- ▶ **Safe lifting and handling** at height.
- ▶ Adaptable to complex wall geometries.
- ▶ **Large and protected working platforms.** Safe access.
- ▶ **Hydraulic system fully configurable** to construction needs.



- ▶ **High load-bearing capacity. Large formwork assemblies can be lifted easily.**
 - Hydraulic power unit operates up to 12 cylinders simultaneously.
 - The working load of each cylinder can be controlled separately.
- ▶ **Roll-back system** allows work to be performed between formwork panels.
- ▶ Main accessories are shared throughout the entire ATR product range.
- ▶ **Compatible with all vertical formwork systems and the MK system.**



ATR-B SELF-CLIMBING BRACKET

Self-climbing **bracket configuration.**

Formwork panel equipped with roll-back carriages (70 cm) set on the bracket itself.

Includes components to position and plumb the formwork both horizontally and vertically.

Two platforms: a main working platform (2.5 m wide) and a platform for hydraulic system operation. Up to three optional platforms for pouring, material recovery, and other tasks.

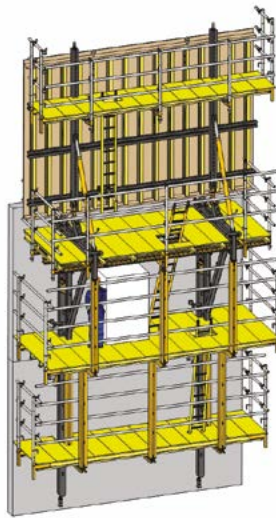

► Main ATR-B system components

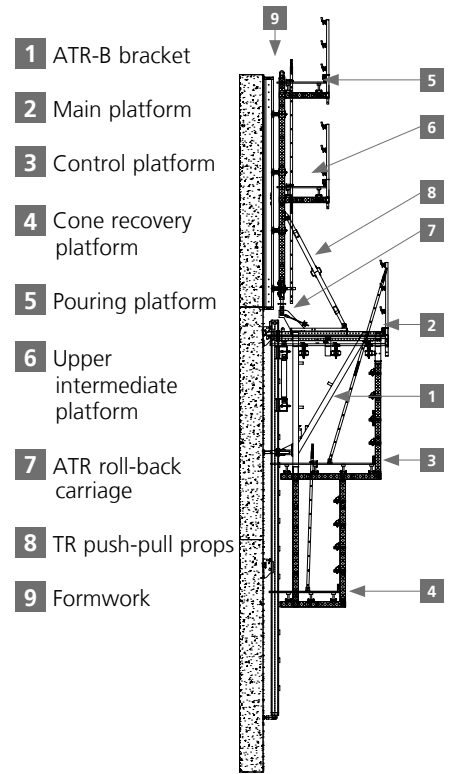

ATR-N NARROW SELF-CLIMBING BRACKET

Used in narrow spaces between walls.

Widths between 1.75 and 2.5 m.

Formwork is hung from a structure above to facilitate stripping, roll-backs, and positioning.

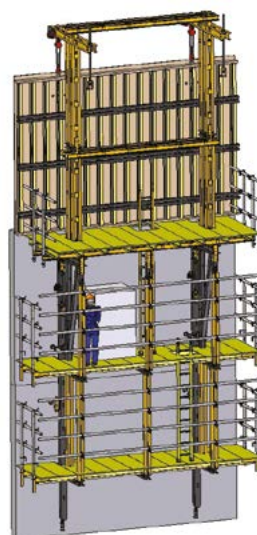

► Main ATR-N system components

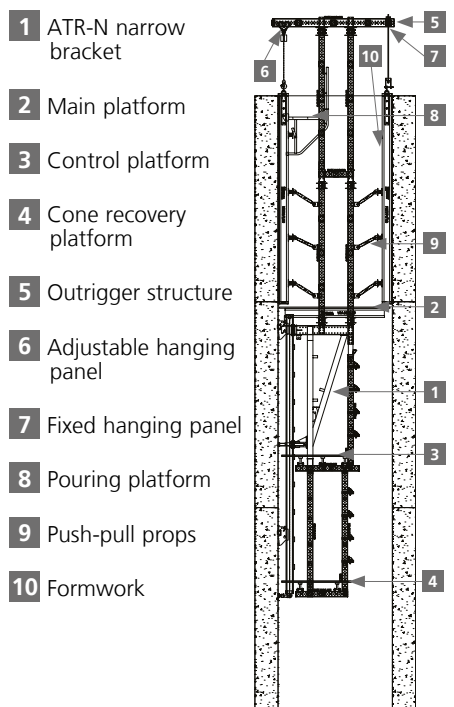



ATR-P SELF-CLIMBING PLATFORM

Platforms used in large spaces when required for reasons of size, loads, or shape.

Structure based on MK system. Adjustable to fit different geometries and formwork roll-back systems (carriages or outrigger structures).

Allows for the installation of boom pump support structures.

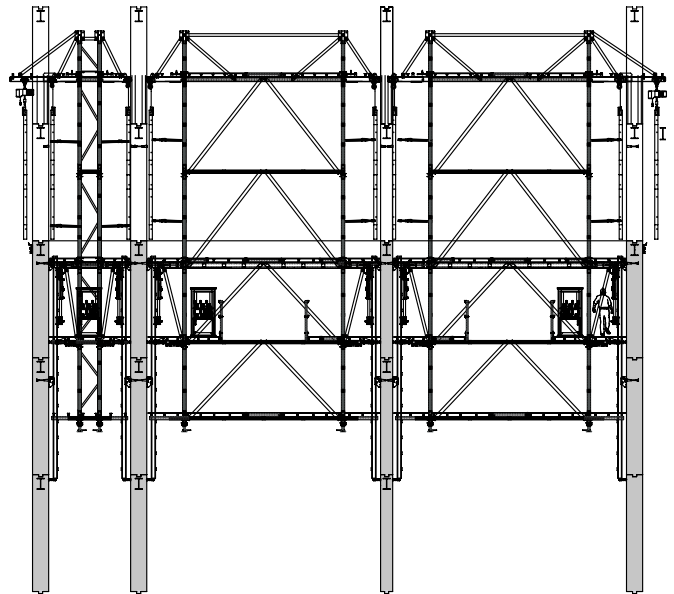

ATR self-climbing system lifting sequence

- 1 Pouring
- 2 Stripping
- 3 Placing of anchors
 - Mast elevation
 - Lower anchor recovery
- 4 Structure elevation

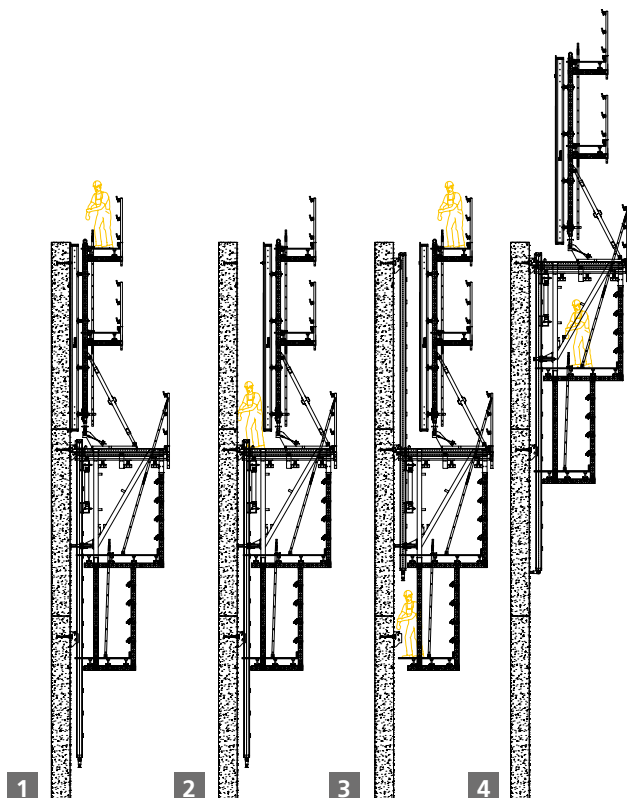



// Solutions

- ▶ **Complex geometries:** based on the MK system, it easily adapts to the building geometries. Customised access, working and storage areas can be configured. They cover the entire perimeter and provide completely safe working areas.



- ▶ **High capacity self-climbing structures for interior shafts:** enables the simultaneous construction of slabs and walls thus reducing material and avoiding the otherwise required connection.





▶ ATR system used in pier construction



▶ Exterior and interior formwork free from interferences above



▶ Guaranteed safety on all working levels



▶ ATR used in inclined pylon construction



RKS Rail Climbing System

// Features

It enables the climbing of the panel without separating the structure from the wall.

Ensures safe lifting operations in any weather conditions. Hydraulic lifting system for formwork assemblies, with crane lifting optional.

Single lower platform for anchor recovery.

Adjustable to different pouring heights, with a standard range from 2.7 to 5 m.

Hydraulic cylinder lifting capacity: 50 kN.



// Main system components

- 1 Formwork
- 2 Additional profile RKS
- 3 Wall bracket LT HWS
- 4 Head LT HWS
- 5 Mast shoe RKS

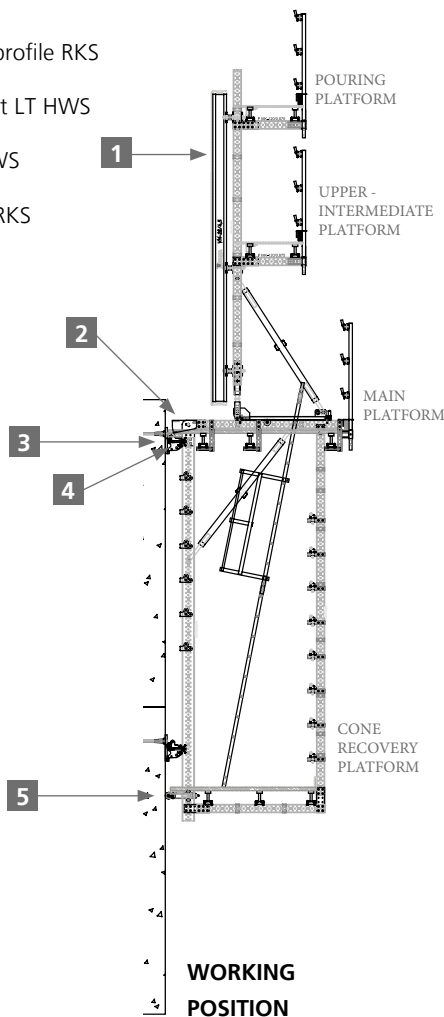

- 1 Vertical waler
- 2 Mast
- 3 Initial pushing mast RKS
- 4 Climbing head HWS
- 5 Cylinder HWS
- 6 Roll-back carriage MK-120
- 7 Hydraulic power unit HWS

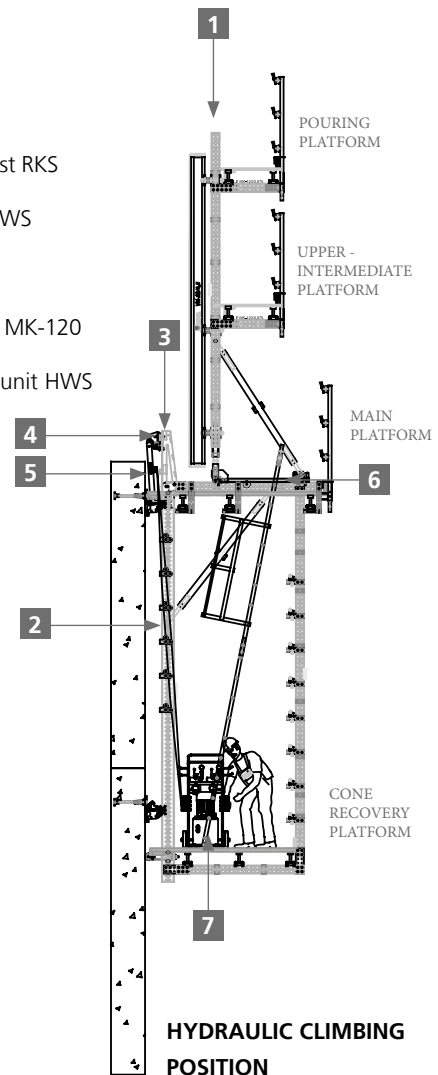



// Benefits

- ▶ **Configuration optimised to obtain high levels of efficiency** on-site.
- ▶ **Single-point rail anchors.**
- ▶ **Safe climbing at height** ensured by rails attached to wall.
- ▶ **Versatile and adaptable** (based on MK system).
- ▶ **Large and secure platforms**, with customisable configurations.
- ▶ **Lifting without crane assistance.**
- ▶ Climbing assemblies lifted with a single hydraulic unit and two portable cylinders.
- ▶ Lifting under **adverse weather conditions.**

// Solutions

▶ Inner cores construction.

Inexpensive system for cores construction without requiring a crane and protecting the workers against the inclemency of the weather.

▶ Construction of buildings with perimeter walls.

Large formwork areas with guaranteed safety and high performance rates.

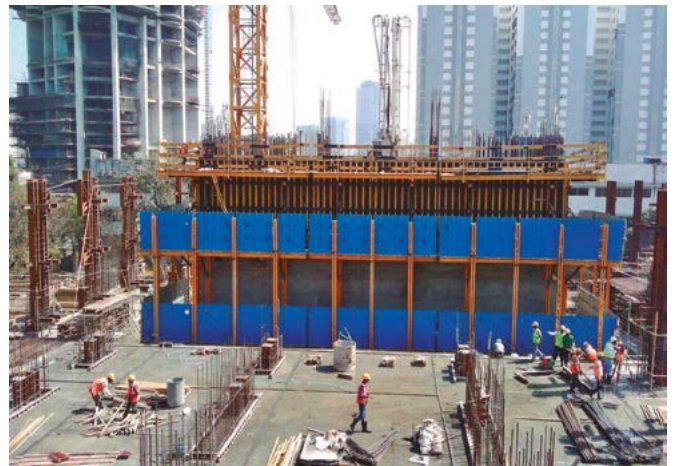



► Construction of partial walls in combination with the HWS Hydraulic Windshield.

Complete enclosure of the building perimeter for safe formwork solutions in wall areas or columns at the slab edge.



► Curved walls.

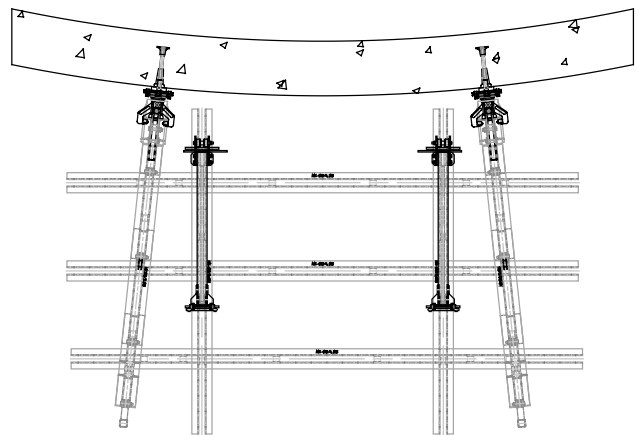

► Great versatility, different types of solutions depending on features of the system.

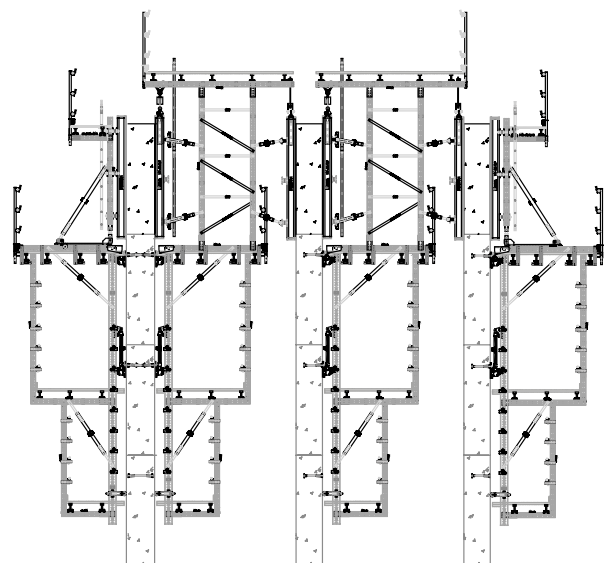
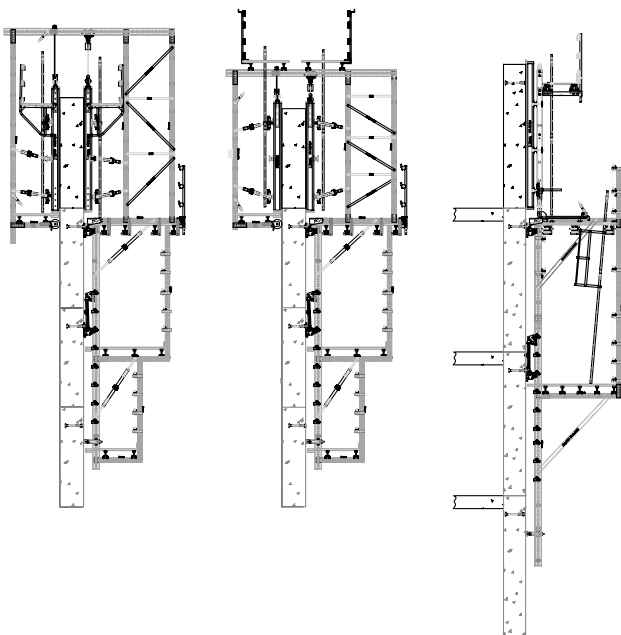
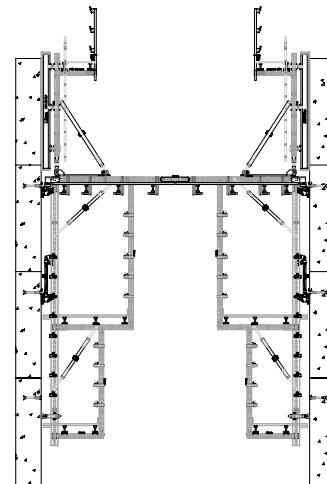



HWS Hydraulic Windshield System

// Features

Safety component for highrise building perimeters.

Covers the floor under construction and the floors immediately below.

Based on MK system (standard walers with simple connecting elements). Adaptable to different geometries and configurations according to requirements.



// Main system components

- 1 Protection screen with different enclosures
- 2 Hydraulic power unit
- 3 Mast
- 4 Slab bracket LT HWS
- 5 Head LT HWS
- 6 Cylinder HWS
- 7 Climbing Head HWS

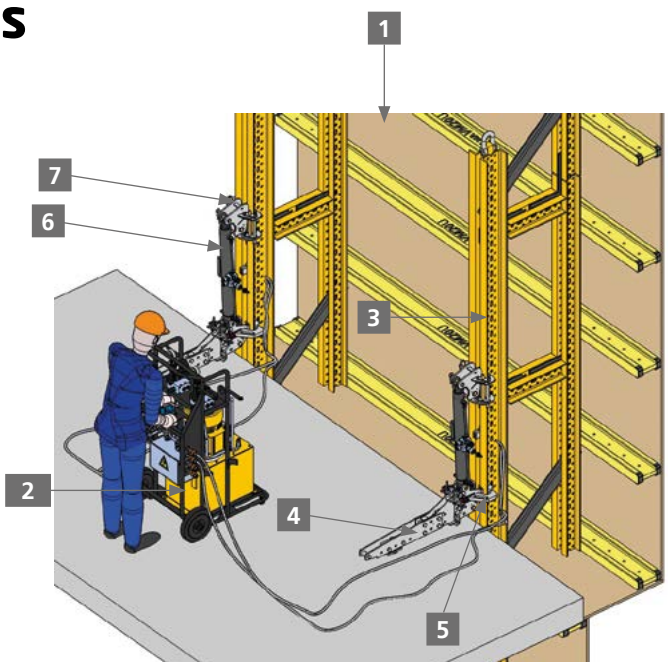



// Benefits

- ▶ **Prevents falls** from the slab edge.
- ▶ Excellent **protection against inclement weather**.
- ▶ Protects against workers experiencing fear of heights.
- ▶ **Flexibility** of the MK system.
- ▶ **Configurable cross-section**: working platform levels, dimensions, material unloading platforms and type of protective sheathing.
- ▶ **Adaptable protective sheathing** (opaque or semi-transparent, stiff or elastic, etc.).
- ▶ Allows for the use of **exterior material lifting platforms**.
- ▶ **Provides access** between the final storeys of the building.
- ▶ **Platform for work** on the slab edge.
- ▶ **Hydraulic self-climbing system** operates without crane assistance.
- ▶ **Can be anchored to slab or wall**.
- ▶ **Adapts well to the geometry of irregular slabs**.
- ▶ Completely encloses the entire perimeter.
- ▶ Accessories shared with other MK solutions.

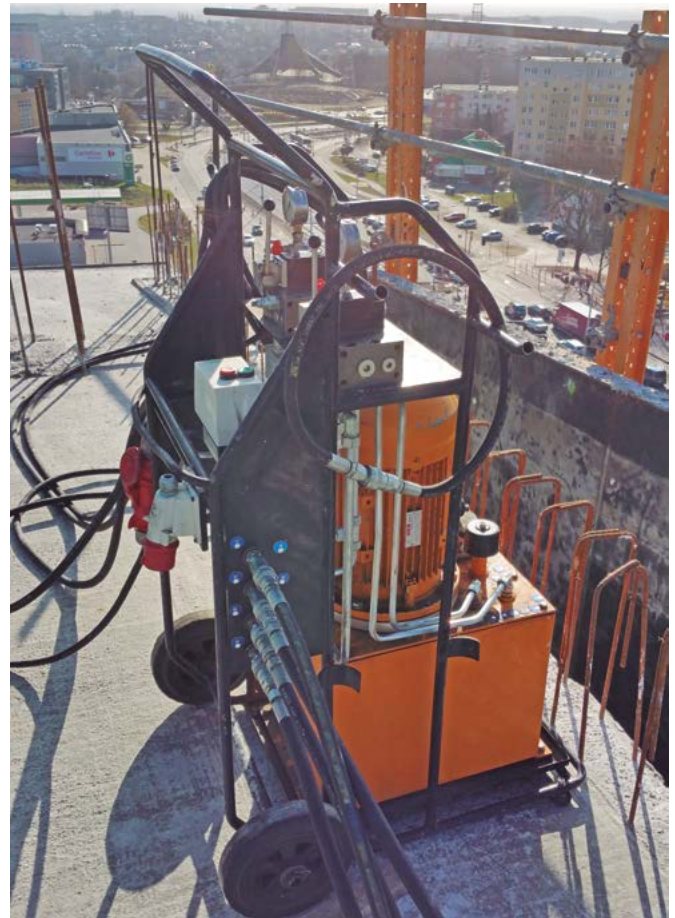

▶ Self-climbing system, hydraulic power unit and cylinders



▶ Installation of HWS windshields

▶ Anchorage of HWS to slab or wall:

1.- Slab anchor system

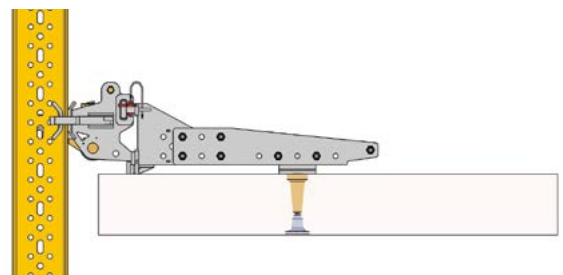

2.- Wall anchor system

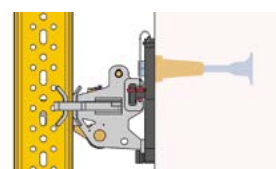



// Solutions

► HWS with **material storage and lifting platforms** at different levels, and **working platform**.

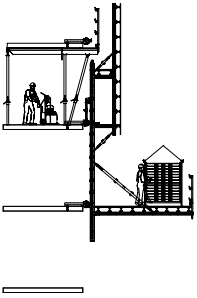

► **Basic cross-section with platform** for material unloading.

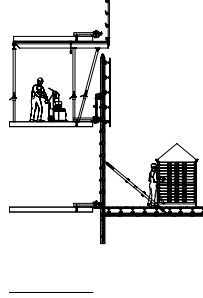

► **Debris section:** slab extension for use as perimeter working platform and material storage area. Prevents debris from falling during formwork table removal and provides a large advertising area directed toward the street below.

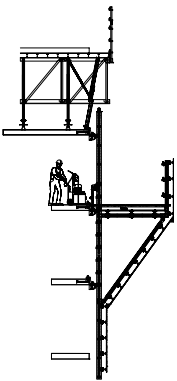

► **Straight cross-section.**

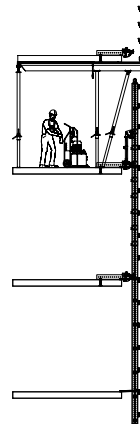

► **Access stairways** in HWS protection.

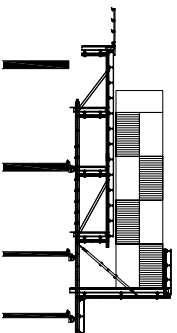

► HWS with **working platform**.

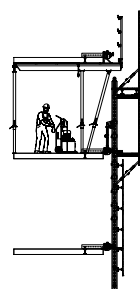



Basic components ATR

ATR-B bracket	0335240	380

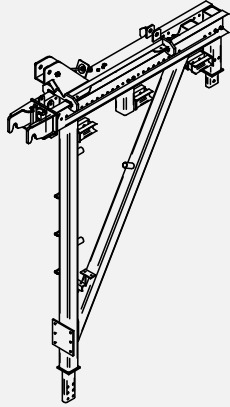

ATR-B bracket body	0335245	263
--------------------	---------	-----

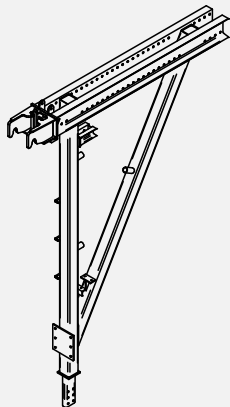

ATR-N narrow bracket	0335250	206
----------------------	---------	-----

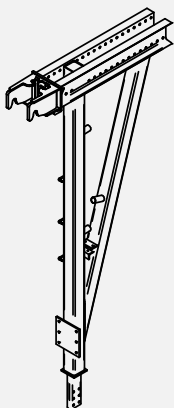

Roll-back carriage ATR	0335066	65
Roll-back rack	0335048	7.3
Gear device	0335126	5.7

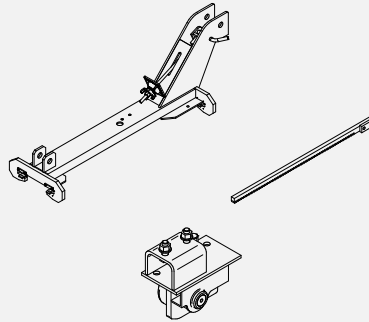

Selfclimbing bracket shoe NV	0335130	61
------------------------------	---------	----

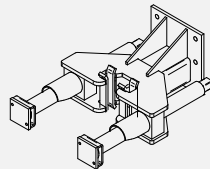

Telescopic head ATR-P	0336000	218
-----------------------	---------	-----

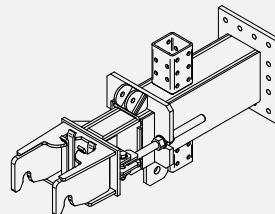

Beam DU-240 ATR-P		
-------------------	--	--

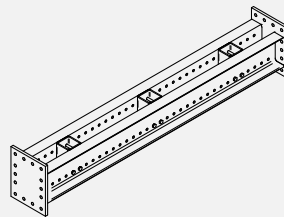

Upper climbing head NV	0338002	31.2
------------------------	---------	------

Lower climbing head NV	0338071	28.8
------------------------	---------	------

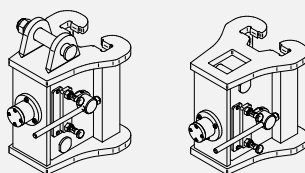

Anchor bracket NC	0339002	21
Double anchor bracket	0339030	23.5

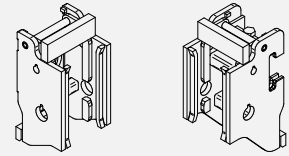

Double cone NC wall anchor	0339024	18
----------------------------	---------	----

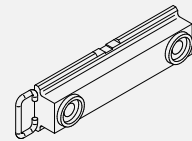

Double cone NC positioner	0339026	1.7
---------------------------	---------	-----

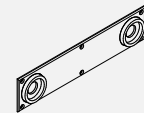

Cylinder ATR 100kN	0338100	45
--------------------	---------	----

Cylinder ATR 130kN	0338142	53
--------------------	---------	----

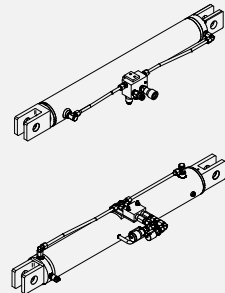

Power unit ATR 6P SFP y 12P SFP		
---------------------------------	--	--

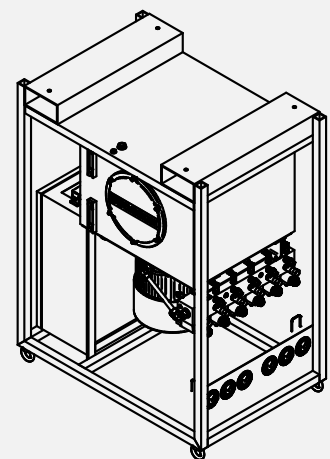



Basic components RKS / HWS

Common			Walers MK-120 (from 1.125 m to 5.875 m)			Main suport RKS		
Head LT HWS	1991169	17.5						
Self-climbing block LT HWS			Profiles MK-180 (from 0.5 m to 10.625 m)			Mast shoe RKS		
Climbing head HWS			Push pull prop E			Swingings shoe RKS		
Cylinder HWS			Spacer tube MK-120/52			HWS		
			Bolt M16 x 90 DIN-931-8.8			Wall bracket LT HWS		
			Nut M16 DIN-934-8.8					
						Slab bracket LT HWS		
						Node slab bracket LT HWS		
Hydraulic power unit HWS			RKS			Ring slab bracket LT HWS		
			Additional profile RKS					
			Initial pushing mast RKS					

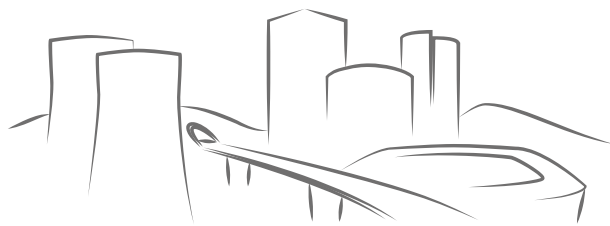

From the beginning of your projects



ULMA C y E, S. Coop.

Ps. Otadui, 3 - P.O. 13

20560 Oñati, Spain

T. +34 943 034 900

F. +34 943 034 920

01B199ENM

►► www.ulmaconstruction.com

IMPORTANT:

Any safety provisions as directed by the appropriate governing agencies must be observed when using our products. The pictures in this document are snapshots of situations at different stages of assembly, and therefore are not complete images. For the purpose of safety, they should not be deemed as definitive. All of the indications regarding safety and operations contained in this document, and the data on stress and loads should be respected. ULMA's Technical Department must be consulted anytime that field changes alter our equipment installation drawings. The loads featured in this document, related to the basic elements of the product, are approximate. Our equipment is designed to work with accessories and elements made by our company only. Combining such equipment with other systems is not only dangerous but also voids any or all our warranties. The company

reserves the right to introduce any modifications deemed necessary for the technical development of the product. All rights reserved. Neither all nor part of this document may be reproduced or transmitted in any way by any electronic or mechanical procedure, including photocopy, magnetic recording or any other form of information storage or retrieval system without the written permission.

© Copyright by ULMA C y E, S. Coop